

# Hinge support - gap 12, axis 9 and 13, rebate 18 mm

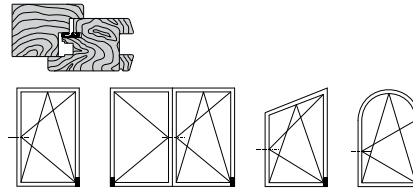
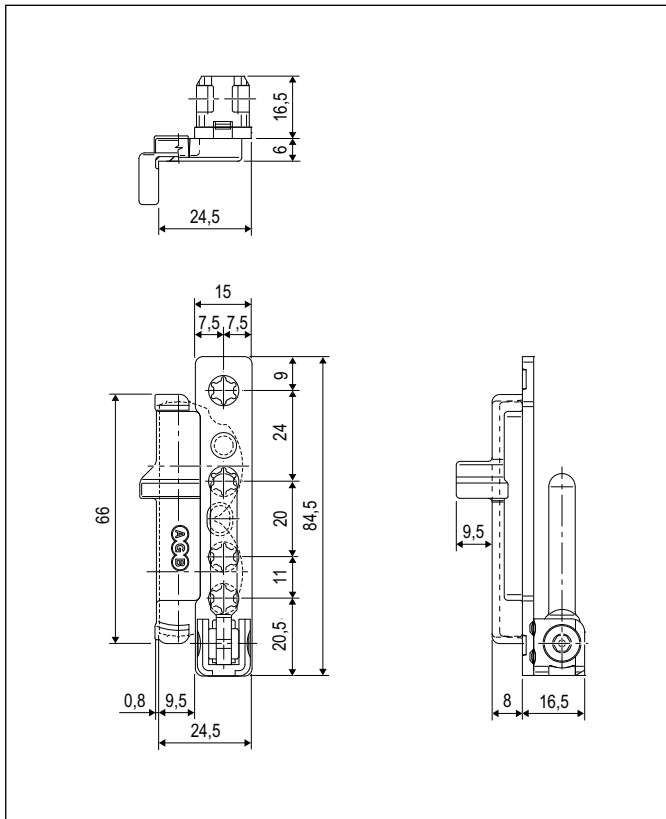

**Description**

Rh and lh male frame part for double  $\varnothing 34$  mm hole drilling.

**Application**

For wooden doors/windows, gap 12 mm, axis 9 and 13, rebate 18 mm. It must be used:  
 - on rectangular, angled, arched windows and balcony doors with one or two sashes.

The housing milling for the hinge in the frame is made completely on the jamb, and for this reason it can be performed on the unassembled frame.

**Mounting**

4x40 mm screws.

**Adjustment**

With 4 mm hexagonal wrench:

- ① horizontal adjustment  $\pm 2$  mm.

**NB.** Use jig A52002.18.00 for drilling holes in the frame if using the corner hinge for windows or jig A52003.18.00/A52004.18.00 is using the corner hinge for balcony doors.

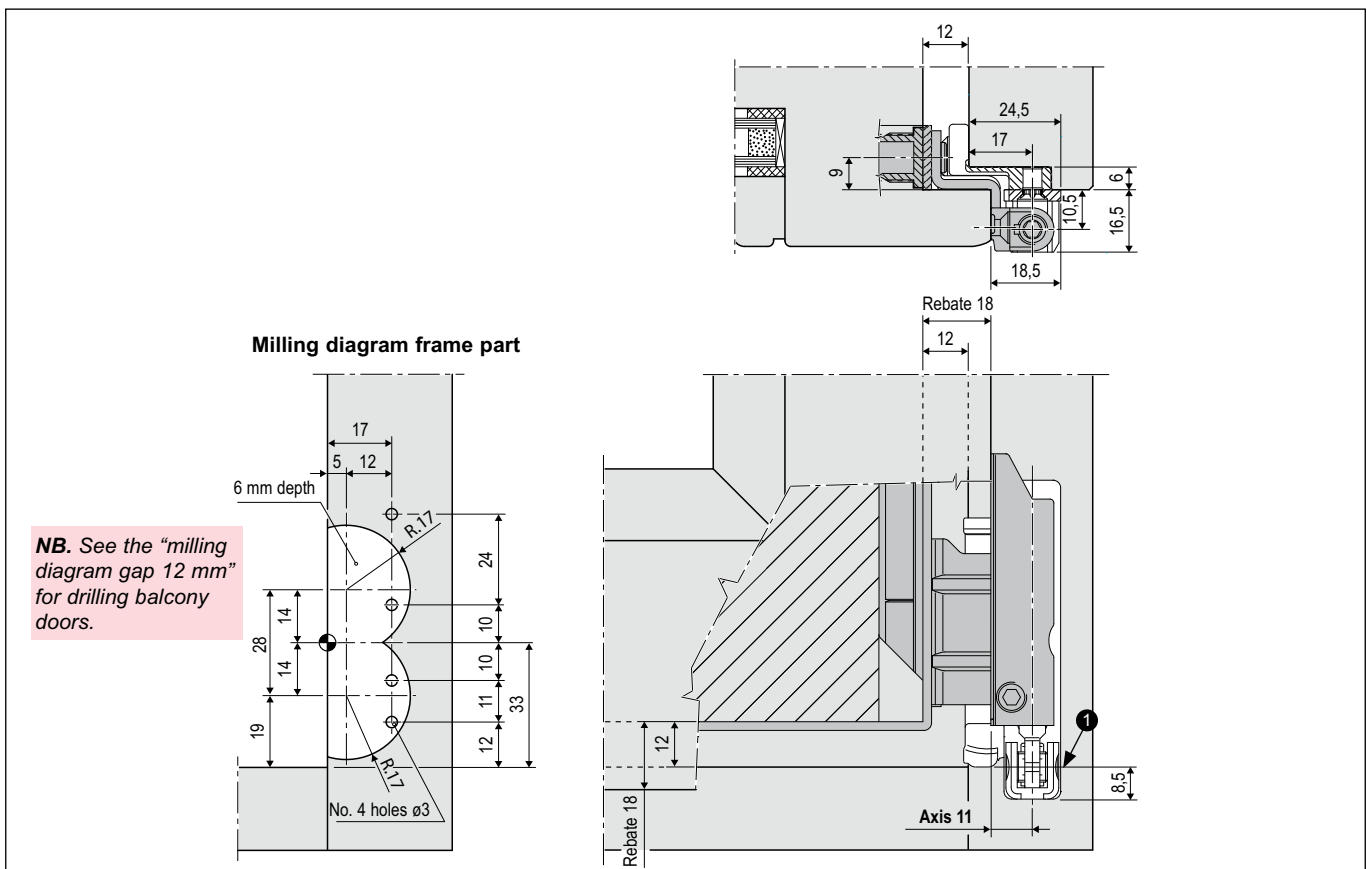

**Order Specifications**

Article	Gap	Axis	Rebate	Type
A50804.05.DX	12	9/13	18	rh
A50804.05.SX	12	9/13	18	lh