

# Fixed pintle with 24 mm plate



### Description

Cold-pressed steel pintle welded to a 24 mm wide shaped steel plate, with pivot axis ranging from 13 to 31 mm based on the GR size.

### Application

For shutters hinged to the soffit or to frames that are flush with the exterior wall or have a slightly recessed reveal, or for monobloc systems with folding shutters. Used in combination with fixed hinges or hinges with horizontal adjustment, to be chosen based on the shutter design.

When selecting the GR size, keep in mind that the F thickness of the rebate or of the shutter overlap, added to the H dimension of the hinge neck, must be equal to the B distance between centres of the pintle. See also the "Application Range" chapter.

### Mounting

Use three 4,5x35 mm screws with suitable thread.

**Note.** In order to position the pintle, both the jig H00930.01.01 (separate frame and sash drilling) and H00930.02.01 (simultaneous frame and sash drilling).

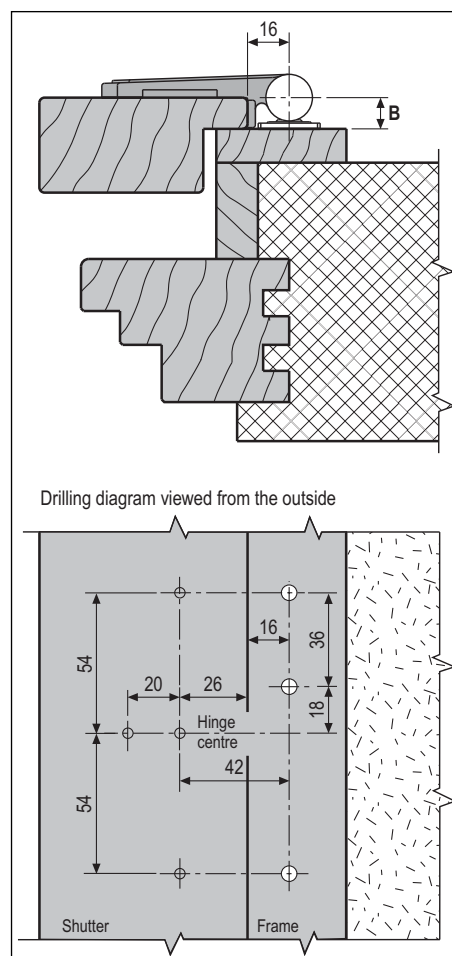
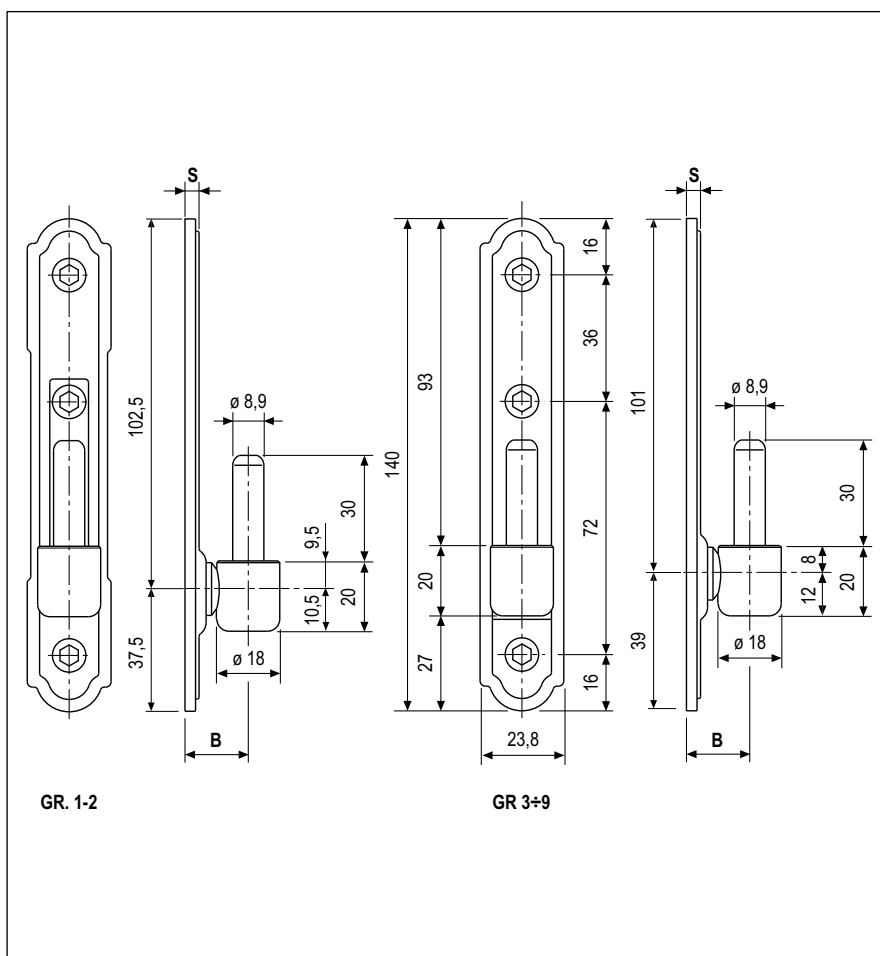

### Order Specifications

GR	B	S	Article
1	13	2,7	H00924.12.XX
2	16	4	H00924.15.XX
3	19	4	H00924.18.XX
4	21	4	H00924.20.XX
5	23	4	H00924.22.XX
6	25	4	H00924.24.XX
7	27	4	H00924.26.XX
8	29	4	H00924.28.XX
9	31	4	H00924.30.XX

**Note.** Refer to the price list in force to check the availability of the finishes.