

Uni-V central point kit

Description

Universal central point kit for all the AGB sliding systems.

Use

The use of Uni-V central point offers many advantages:

- it binds the sashes in closing position;
- keeps the production fast because it doesn't need gasket holder profiles;
- helps the system tightness thanks to the increased gasket;
- helps the sash sliding thanks to wide working tolerances which are able to compensate the natural deformation of wood.

Fastening

- a) Cut the components (follow the technical manual indications for each sliding system);
- b) insert the gasket;
- c) insert the terminal caps;
- d) fasten the profiles to sashes using screws $\varnothing 3,5 \times 35$;
- e) insert the screws covering profiles and the brush;
- f) silicone and cut following the indications of the specific technical manual for each sliding system.

Materials

- 1) EPDM gasket,
- 2) Covering profiles of screws in PVC,
- 3) Extruded aluminium profiles,
- 4) Polypropylene brush.

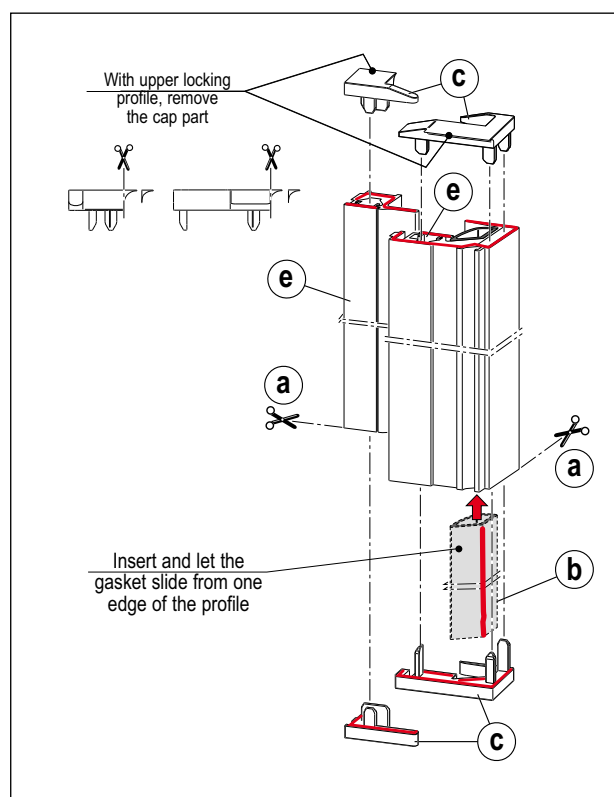
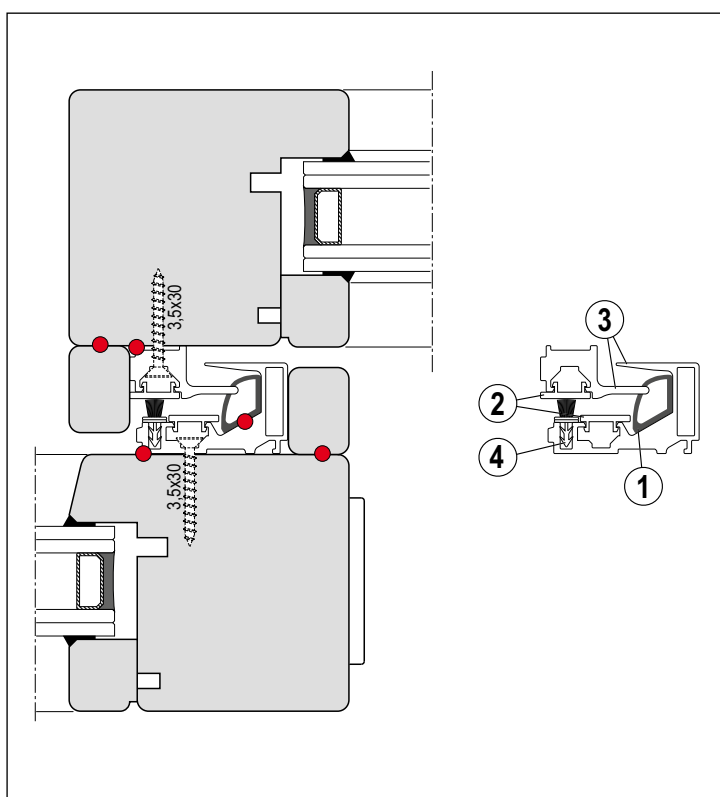

Ref.	Article	Article code	Finish	Length
1	Uni-V point profile	G02208.25.01	Silver	2500 mm
		G02208.25.93	Black	2500 mm
		G02208.31.01	Silver	3100 mm
		G02208.31.93	Black	3100 mm
		G02208.40.01	Silver	4000 mm
		G02208.40.93	Black	4000 mm

Ref.	Article	Article code	
2	Caps kit	G01610.DX.93	Right
		G01610.SX.93	Left