

Locking pins

Article	Pos.	Description	Material	Use	Fastening
Locking pins	<ol style="list-style-type: none"> 1 2 	Cold pressed steel pins.	Steel	Fastened to the frame jamb, they are used as a safe locking point for the sliding sashes. They are available in the wood version or in version PVC and aluminium.	Pre-hole, 10 mm diameter, for soft wood.
					Pre-hole, 11 mm diameter, for hard wood.
Pins in microventilation position	3	Pins with double closing position. It allows to close the sash to the frame with a gap for ventilation.			Fasten the pin using the dedicated hook G00746.00.06.
			Attention: don't use the hammer because it could damage the pin tightness.		
			Register using the key A20019.00.05 later.		
			<p>Note: to determine the correct locking pin placement, use the jig G00746.00.05 (see the chapter "Jigs").</p>		

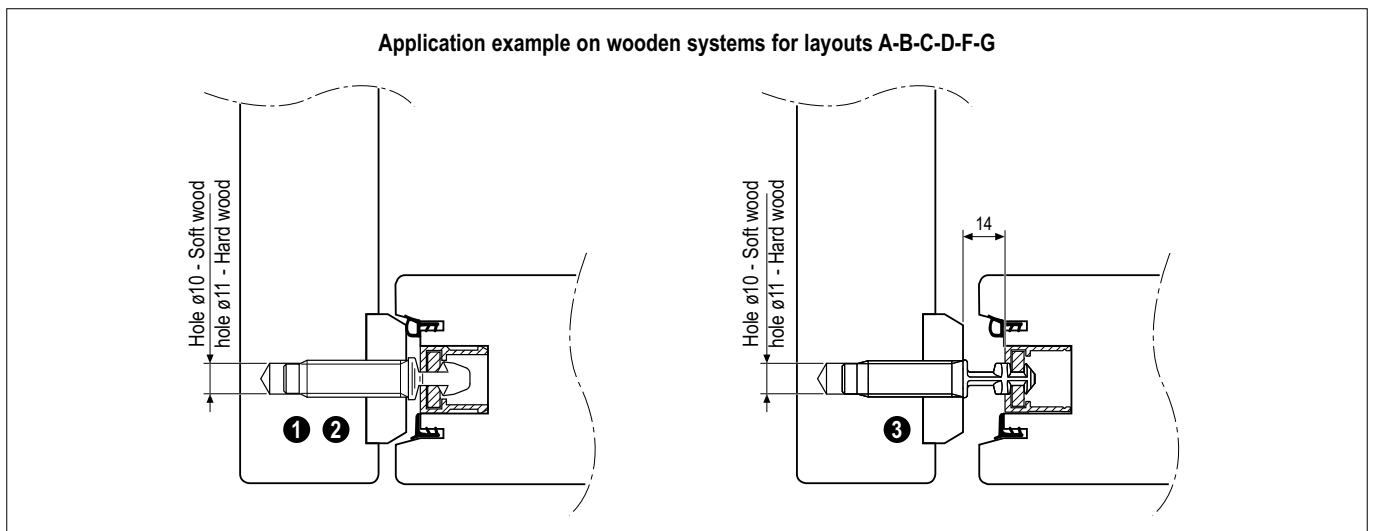
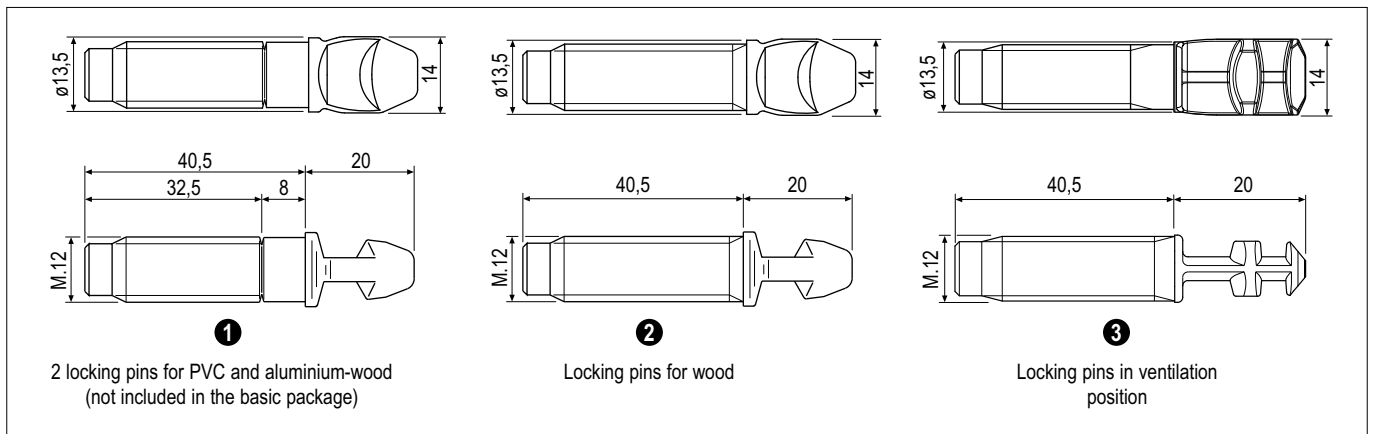

Ref.	Description	Code
1	PVC/Aluminium-wood	G00728.00.02
2	Wood	G00728.00.03
3	Ventilation for PVC/Aluminium-wood/Wood	G04902.01.00