

Tilt striker with concealed screws

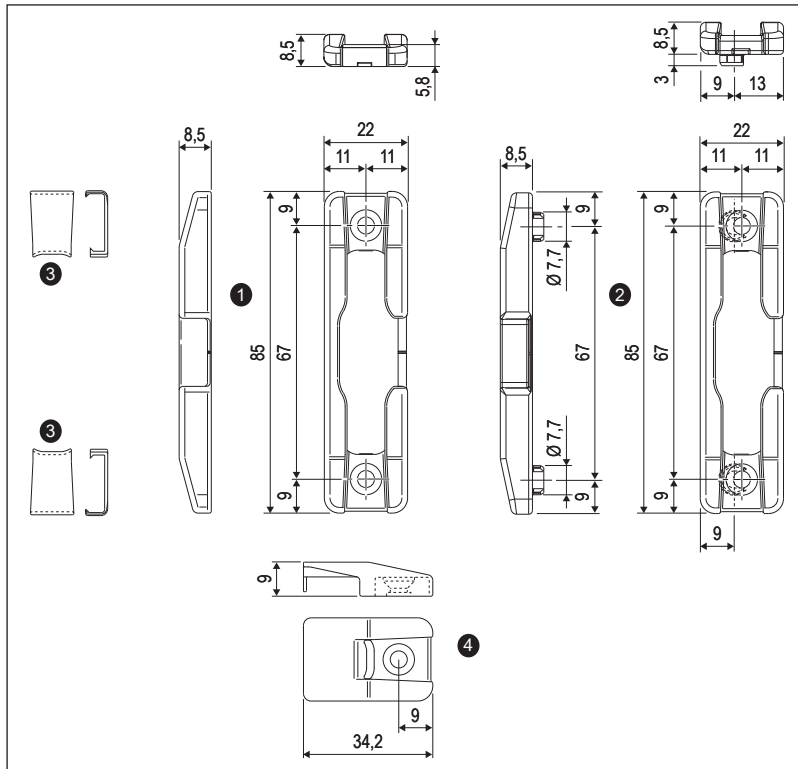

12 mm gap, 13 mm axis,
24 mm rebate base
(30 mm rebate base version
A52200.CR.70 only)

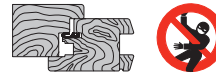

Opening	Tilt&Turn, 1 and 2 sashes
Stroke	18+18 mm
Material	Zamak
Fastening	2 screws of $\varnothing 3,5$ up to $\varnothing 4$ mm

Description

Non-handed tilt striker.
Available accessories:
③ screws cover clips;
④ lifting device.

The lifting device is suggested for the primary sash because it gives a support in Tilt position (when the DSS doesn't work) and for the second sash: it avoids failures when the weight of the first sash is loaded to the second sash by the DSS.

When used with magnetic cam corner drives, it is possible to place, below the striker, two sensors (A39406.11.00 or A39406.21.00).

The magnetic sensors are able to read the cam magnet presence even if the striker base hasn't been drilled.

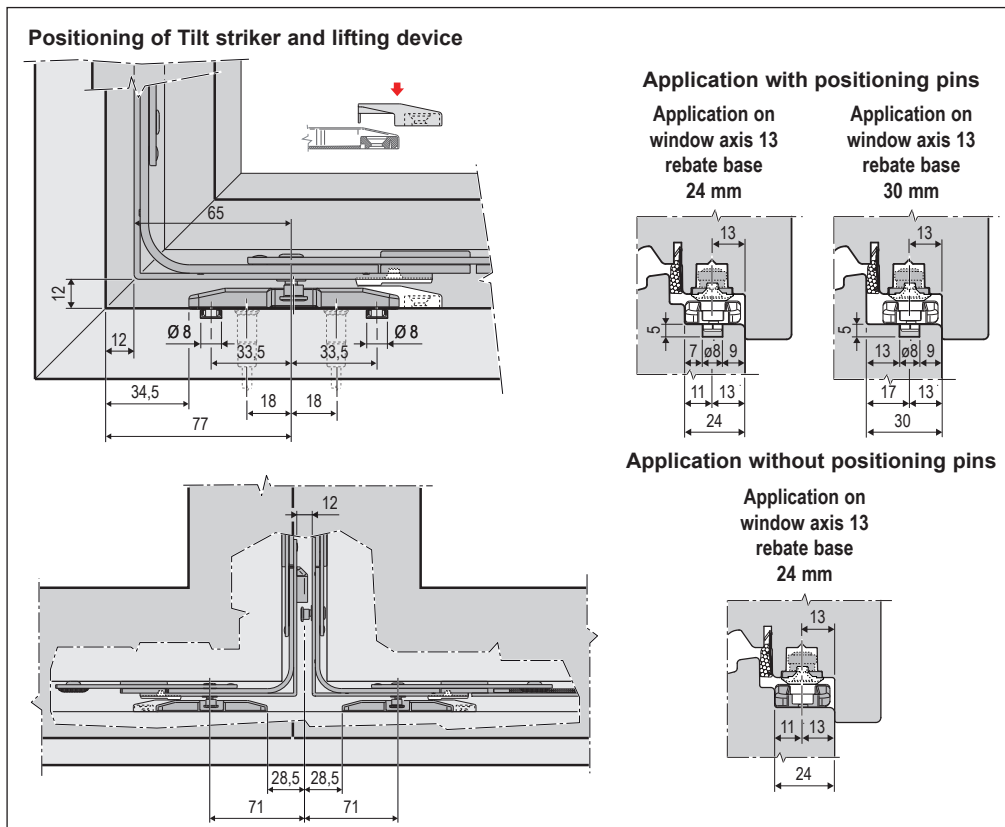

Order specifications

Ref.	Article	Dimensions mm	Description
①	A51400.CR.70	22x85x8,5	tilt striker
②	A52200.CR.70	22x85x8,5	tilt striker with positioning pins
③	A52102.02.XX	-	covers for tilt striker
④	A52103.01.XX	-	lifting device

Note. Refer to the price list in force to check the availability.