

ZENIT

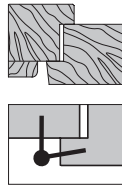

Description

Adjustable hinge made of galvanised steel, 16 and 20 mm in diameter, featuring threaded pins with 1,8 mm pitch, maximum stripping strength, easily screwed down into wood.

Adjustments: can be adjusted horizontally using a 5 mm Allen wrench and vertically with a 4 mm Allen wrench.

- 1 Horizontal adjustment: made by adjusting the threaded pins when screwing them down.
- 2 Depth adjustment: made by adjusting the threaded pin on the lower body (to apply the proper pressure to the gasket).
- 3 Vertical adjustment: 4 mm, through the thrust applied by a tapered screw onto the revolving ball set in the mobile pivot.

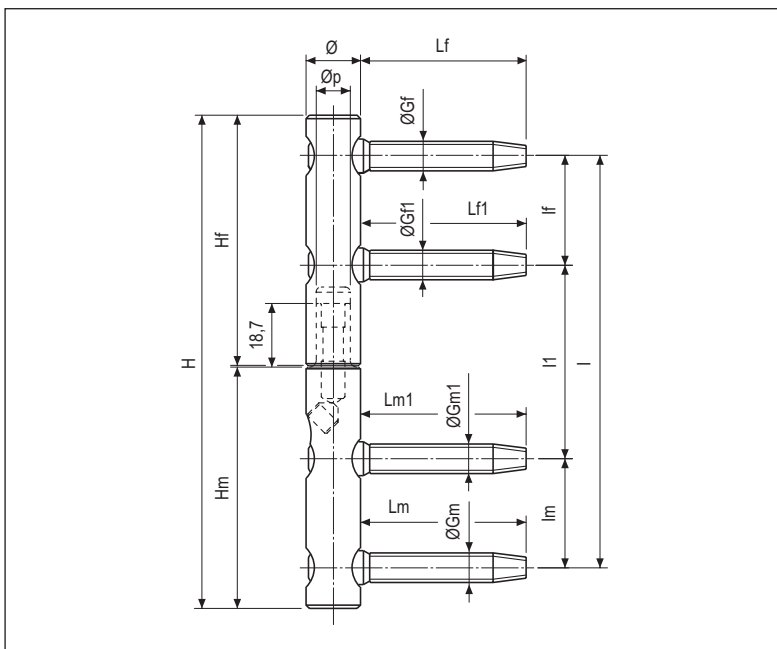

Hinge measurements

Dimension	Diameter (Ø)	
	16	20
H	145	145
I	121	121
Hm	71	71
Hf	73,5	73,5
Øp	10	13
ØGm	8,8	9,3
Lm	48,5	53,5
ØGf	8,8	9,3
Lf	48,5	53,5
Im / If	32	32
I1	57	57
ØGm1 / Gf1	8,8	9,3
Lm1 / Lf1	48,5	53,5

Order specifications

Material	Article
STEEL	E02150.16.XX
	E02150.20.XX

NB. Refer to the price list in force to check the availability of the finishes.

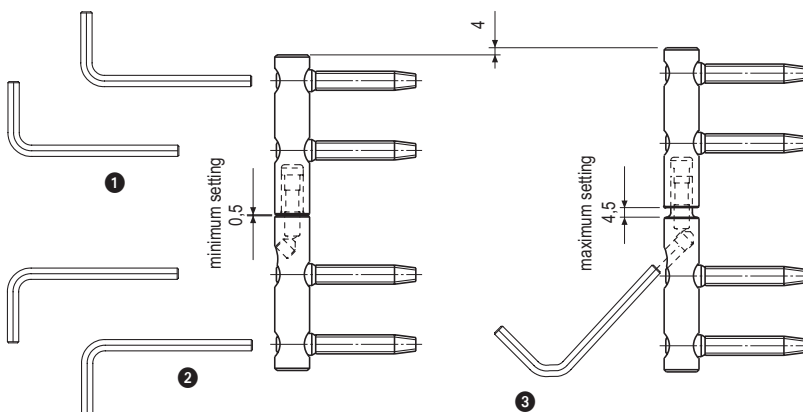

INSTALLATION TOOLS ("Jigs" chapter)

- Guide tool box article code E00112.XX.05
- Guide tool kit article code E00165.XX.05
- Single jig for frame drilling article code E00139.XX.05
- Jig rod for door windows article code E00136.00.21 (r.h.)

Available covers

	BRASS: Art. E02152 for ø16-20 mm
	ABS: Art. E02151 for ø16-20 mm

NB. For complete dimensions and codes, see the "Covers" chapter.

